

PUNCH, STEPPED, SQUARE, ~ DIN 9861

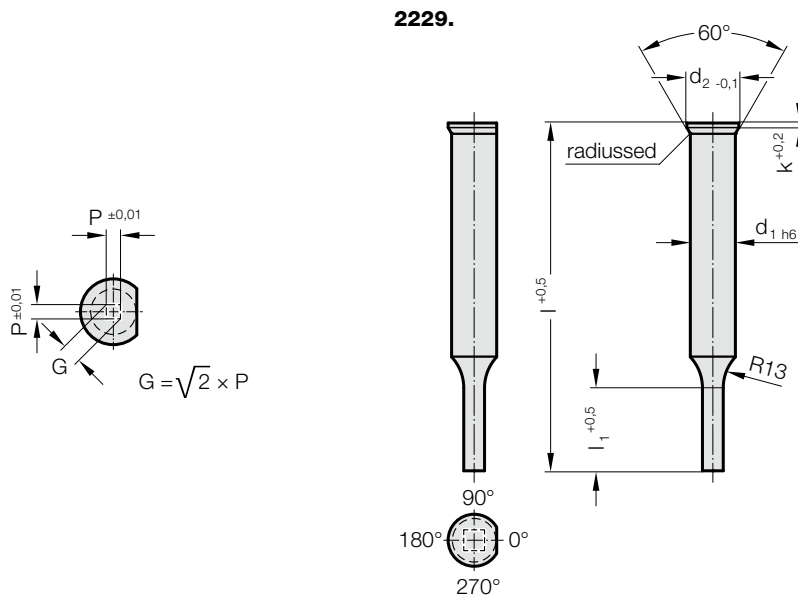

2229. Punch, stepped, square, ~ DIN 9861

d ₁ / Order No	d ₂	P _{min}	G _{max}	l ₁ / Order No	k	l (Order Code character)	71 (D)	80 (E)	100 (G)	120 (J)
3 / (1)	4.5	0.5	2.9	8 (1) 10 (2)	0.5		●	●	●	●
4 / (2)	5.5	0.8	3.9	8 (1) 13 (3)	0.5		●	●	●	●
5 / (3)	6.5	1	4.9	13 (3) 19 (4)	0.5		●	●	●	●
6 / (4)	8	1.6	5.9	13 (3) 19 (4)	0.5		●	●	●	●
8 / (5)	10	2	7.9	19 (4) 25 (5)	1		●	●	●	●
10 / (6)	12	3.5	9.9	19 (4) 25 (5)	1		●	●	●	●
13 / (7)	15	4.5	12.9	19 (4) 25 (5)	1		●	●	●	●
16 / (8)	18	6	15.9	19 (4) 25 (5)	1.5		●	●	●	●
20 / (9)	22	8	19.9	19 (4) 25 (5)	1.5		●	●	●	●

Ordering Code (example):

2229.39E5.1550.B

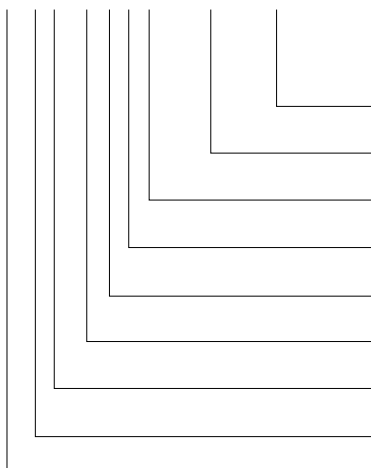

Angle:
90°

Shape: square, Length P
P = 15,5 mm

Punch cutting length: l₁
25 mm

Length: l
80 mm

Diameter: d₁
20 mm

Material:
HSS

Type:
DIN 9861

Execution: Order No
square

Punch:
without ejector pin

Order Code character
= (B)

= 1550

Order No
= (5)

Order Code character
= (E)

Order No
= (9)

Order No
= (3)

Order No
= (9)

= (2)

= 22

Material:

HSS
Order No 2229.3.
ASP 2023
Order No 2229.6

Hardness:
Shaft 64 ± 2 HRC
Head 52 ± 5 HRC

Description of FIBRO materials for tool and die components see at the beginning of Chapter E.

Execution:

Punch head heat compressed. Contact area, shaft and cutting form precision ground. The locating flat is designed parallel with the dimension P = 0°.

Note:

With kerf ≤ 0.04 mm, FIBRO rounds off sharp edges, if the punch and bush are ordered together. This reduces the fitting time and the risk of an edge break during operation.