

PUNCH WITH TAPERED HEAD 30°, SHAPE C

2291.

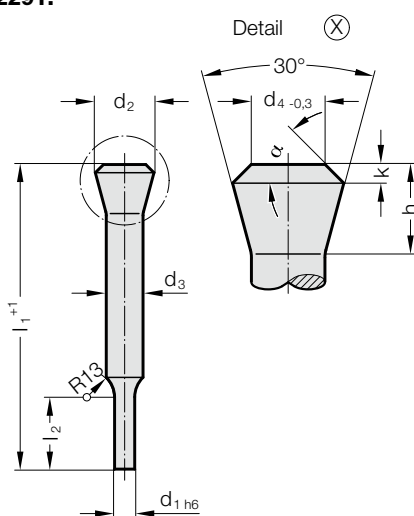

Material:

HSS

Order No 2291.3.

Hardness:

Shaft 58 + 2 HRC

Head ≤ 50 HRC

 Description of FIBRO materials for tool and die components see at the beginning of Chapter E.

Execution:

Head hot upset-forged and tempered. Shaft and head subsequently precision plunge-ground for perfect concentricity and full interchangeability with replacement punches.

d₁ and l₂ to customer's specifications!

2291. Punch with tapered head 30°, Shape C

d ₃	d ₂	d ₄	h	k	α ± 1°	l ₁	100	120
5.5	8.98	5.5	7.5	1	30		●	●
6	9.75	6	8	1	28		●	●
8	12.8	8	10	1	22.5		●	●
9	14.4	9	11	1	20		●	●
10	15.9	10	12	1	19		●	●
12	18.7	12	14	1.5	24			●
14	21.8	14	16	1.5	21			●
16	24.6	16	18	2	25			●

Ordering Code (example):

Punch with tapered head 30°, Shape C	=	2291.
Material MAT	HSS	= 3.
Shaft diameter d ₃	10 mm	= 1000.
Length l ₁	100 mm	= 100.
Cutting diameter d ₁	5 mm	= 0500.
Cutting length l ₂	5 mm	= 005
Order No		= 2291. 3.1000. 100.0500. 005