

# SETTING-UP BUMPER, ROUND

2531.7.

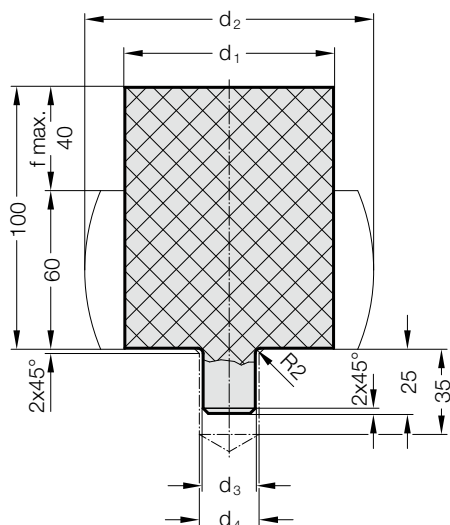

## Description:

Setting up bumpers are used for setting down and setting up tools and replace shear pins.

## Material:

FIBROFLEX®

Hardness 95 Shore A

## Attention:

Setting up bumpers are not suitable for continuous use. To prevent damage when setting down tools, ensure that the setting up bumpers are large enough to withstand 1.5 times the weight of the tool (see table).

## Implementation:

1. When setting up slowly move the ram into the bottom position.
2. Clamp the tool, then move the ram back to the top position (with the setting up bumper compressed to a height of 60 mm).
3. After setting up, remove the setting up bumpers and place them in the storage hole on the tool.

## Mounting example

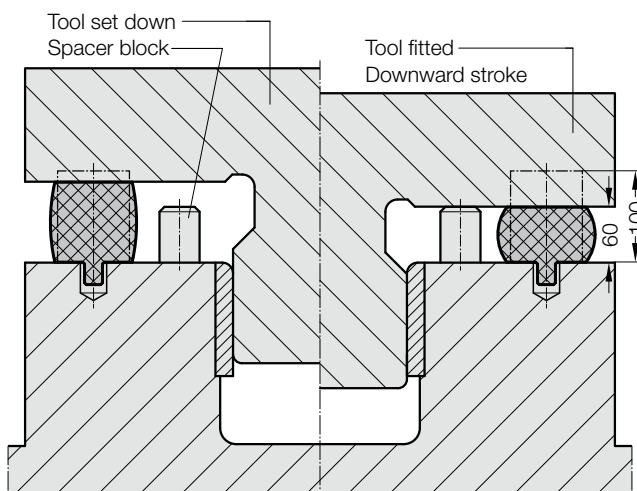

## 2531.7. Setting-up bumper, round

Order No	d <sub>1</sub>	d <sub>2</sub>	d <sub>3</sub>	d <sub>4</sub>	f max.	Load capacity	Load capacity	Load capacity	Admissible tool weight in kg for 4 setting up bumpers f=20/safety factor 1,5
						in daN bei f=20	in daN bei f=25	in daN bei f=40	
2531.7.063	63	86	16	18	40	2,200	2,800	4,800	5,800
2531.7.080	80	111	20	22	40	3,500	4,600	8,500	9,300
2531.7.100	100	136	20	22	40	5,000	6,700	11,700	13,300
2531.7.125	125	171	25	28	40	7,600	9,400	18,900	20,200